

# Fiber Optic Solutions for High-Speed Telecommunications, CATV, Wireless and FTTP Networks



TELECOM TUNABLE LASERS & TRANSCEIVERS

FIBER OPTIC LINKS

LASERS

CATV TRANSMITTERS & RECEIVERS

PHOTODIODES

WIRELESS, FTTP

EMCORE is a leading supplier of tunable laser modules and transceivers for 10, 40, 100 and emerging 400 gigabit-per-second (Gbps) telecommunications networks and high-end, high-speed Coherent systems. With our expertise in Indium Phosphide (InP) semiconductor wafer manufacturing, we are one of the few suppliers offering truly vertically-integrated products for the telecom network infrastructure of the future.

For the CATV industry, EMCORE has a long history as an innovator and leader in RF over fiber technology for HFC networks that have enabled cable MSOs to continually expand and enhance their services to meet increasing demands for high-speed Internet, HDTV, video-on-demand, interactive video, plus other advanced services.

EMCORE's latest products for wireless systems support emerging Distributed Antenna System (DAS) applications by enhancing bandwidth to enable delivery of consistent, reliable signals in areas where interference is high, or signals are normally weak.



# Telecom Tunable DWDM Overview

EMCORE's Telecom Tunable DWDM portfolio is based on our proprietary Clearlight External Cavity Laser (ECL) technology platform. Clearlight is a modular platform that allows key elements to be independently optimized, resulting in superior performance. Customization is more readily supported and new products can require only partial redesign for individual customer platforms, resulting in faster design cycles. EMCORE's ECL platform is the foundation of the Coherent roadmap from chip to modules, to Integrated 100 Gbps Transmitter (ICT) platform for CFP2 and beyond.

## Telecom Tunable Highlights

- Vertically-integrated InP solutions
- Modular, proprietary ECL technology platform
- Customizable with faster design cycles
- Industry-leading ITLA
- First micro-ITLA to market
- High-performance Tunable-XFP

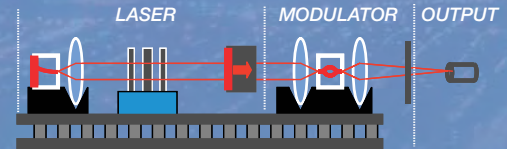

### Tunable Lasers

EMCORE's Integrable Tunable Laser Assembly (ITLA) has been the industry's leading tunable laser source for 40 and 100 Gbps Coherent systems. With the launch of the new micro-ITLA, EMCORE has delivered all the benefits of the ITLA in a form-factor that is three times smaller and requires significantly less power than the standard ITLA.

### Tunable Transceivers

EMCORE's Tunable-XFP Transceiver (T-XFP) empowers the next generation of high-density 10 Gbps metro and long-haul DWDM networks. It is an ideal source to replace legacy 300-pin transponders and fixed-wavelength transceivers. Our top performing T-XFP enables customers to dramatically reduce space requirements, power use, and operating expenses.

## Telecom & Metro Network Applications

### 40/100/400 GIGABIT COHERENT SYSTEMS

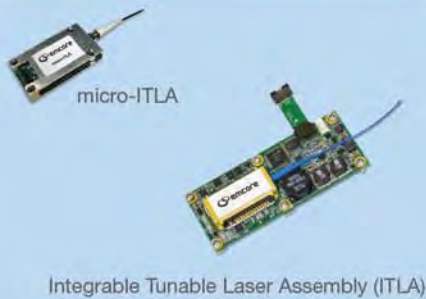

### 10 GIGABIT DWDM SYSTEMS

Full Band Tunable XFP Transceiver

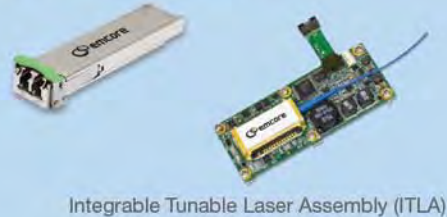

NETWORK KEY — Fiber Optic Interface — Copper/Coax Interface

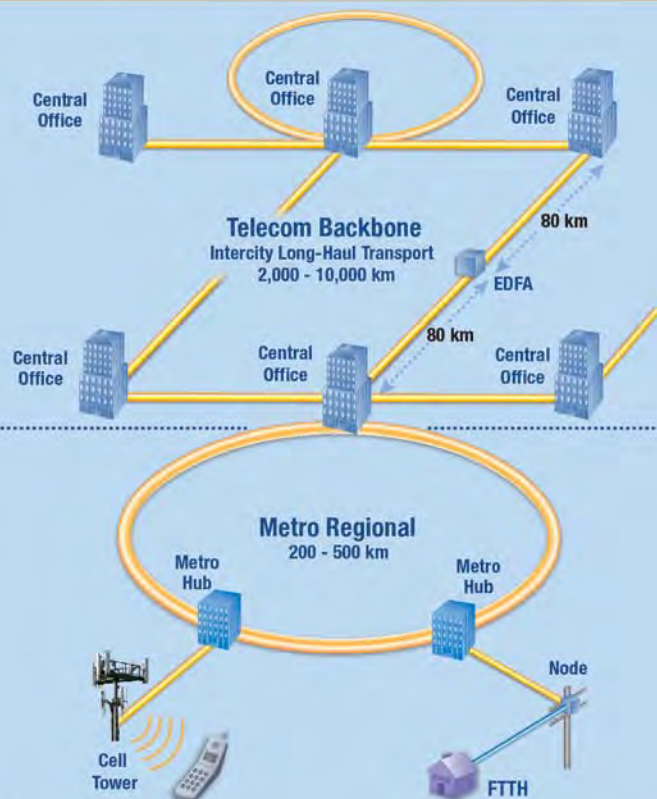



# Telecom Tunable Laser Modules

40, 100 AND 400 Gbps OPTICAL NETWORKING AND COHERENT SYSTEMS

EMCORE's tunable laser modules, based on our ECL technology platform, deliver industry-best performance in frequency control, optical noise, output power, power consumption and frequency accuracy. The ECL design uses thermally-tuned etalon filters to achieve single-mode operation at selectable wavelengths. The EMCORE tunable laser has no moving parts and has a field-proven track record of several billion field-hours.

## micro-ITLA (micro-Integrable Tunable Laser Assembly)

The EMCORE TTX1995 micro-ITLA delivers the high-end performance required for next-generation optical systems enabling 40, 100 and 400 Gbps Coherent transmission links. It is an ideal source for high-speed data rates with an extremely narrow linewidth, low Relative Intensity Noise (RIN), high Side Mode Suppression Ratio (SMSR), and excellent frequency accuracy. Additional features include off-grid tuning, adjustable grid-spacing, in-operation adjustable output power of 6 dB, and a high output power option of 15.5 dBm.

The EMCORE micro-ITLA allows customers to drastically improve density and cost, without sacrificing quality. The smaller form-factor and reduced power consumption enables customers to design higher densities, at lower cost into their 40, 100 and 400 gigabit Coherent systems.

The EMCORE TTX1995 micro-ITLA is fully Telcordia® qualified and complies with industry multi-source agreements (MSAs).



### micro-ITLA Highlights

- Three times smaller than ITLA - 20 x 37 x 7.5 mm form-factor
- Full C- and L-Band tuning - Tune to any grid, any frequency
- Ultra-narrow linewidth: 20 KHz typical
- High SMSR: 55 dB typical
- Low RIN (Relative Intensity Noise): < -145 dB/Hz
- ±2.5 GHz frequency accuracy
- In-operation frequency adjust: ±6 GHz
- Full control and monitoring via RS-232 serial interface

### Applications

- 40, 100 and 400 Gbps Coherent transmission links
- High-channel count DWDM systems

## ITLA (Integrable Tunable Laser Assembly)

The EMCORE TTX1994 Full-Band ITLA is used for Dense Wavelength Division Multiplexing (DWDM) optical transceivers and discrete line card designs. It combines narrow linewidth, low phase noise, high output power and accurate frequency control, making it the industry-leading ITLA for 40/100 Gbps applications. The ITLA complies with the stringent requirements for transponders and discrete line cards

The EMCORE ITLA alleviates inventory and sparing costs in high-channel-count DWDM systems by allowing a single device to replace each of the single-channel devices. Full-band tunable assemblies also enable system functionality such as hot back-up and dynamic provisioning in addition to applications of optical regeneration and wavelength conversion.

The EMCORE TTX1994 ITLA is fully Telcordia® qualified and complies with industry multi-source agreements (MSAs).



### ITLA Highlights

- Full C- and L-Band tuning - Tune to any grid, any frequency
- Narrow linewidth: < 100 kHz
- 3.5 W power consumption
- > 6 dB in-operation power adjustment
- > 45 dB SMSR
- In-operation frequency adjust: ±6 GHz
- SBS suppression
- Full control and monitoring via RS-232 serial interface

### Applications

- 10, 40 and 100 Gbps optical networking
- Cross-connects, optical switches
- DWDM terminals
- WDM metro systems



# Telecom Tunable Transceivers

10 Gbps DATA CENTER, METRO & LONG-HAUL DWDM, 100 Gbps COHERENT SYSTEMS

## Full Band Tunable XFP Transceiver

The EMCORE TXN1811 Tunable XFP (T-XFP) Transceiver empowers the next generation of high-density 10 Gbps metro and long-haul DWDM networks by providing both tunability and pluggability features in the smallest available form-factor.



The T-XFP is built upon EMCORE's proprietary Tunable Transmitter Optical Sub-Assembly (TTOSA), and like our tunable laser modules, leverages EMCORE's field-proven tunable External Cavity Laser (ECL) technology along with an Indium-Phosphide (InP) modulator.

The EMCORE T-XFP is a drop-in replacement for linecards already employing fixed-wavelength XFP transceivers for client-side DWDM applications. With optical performance similar to larger 300-pin MSA transponders, it is also an enabling option for redesigned high-density line-side DWDM network applications.

Tuning over the complete ITU C-Band or L-Band, the EMCORE T-XFP alleviates inventory and sparing costs by allowing a single device to replace all of the single-channel transceivers in a network node. As increasing bandwidth demand continues to push 10 Gbps DWDM closer to the network edge, high-density designs enabled by EMCORE's T-XFP allows for the lowest overall network cost.



EMCORE Tunable TOSA

The EMCORE TXN1811 Tunable XFP is fully Telcordia® qualified and complies with industry multi-source agreements (MSAs).

## Tunable XFP Highlights

- Full C-Band or L-Band tunable transceiver with 100 channel tuning range
  - 40 nm (100 x 50 GHz channels)
- ITU Flexi-grid compliant - tune onto any frequency grid
- Negative and zero chirp transmitter options
- Excellent low-OSNR performance
- 45 dB SMSR
- < 3.5 W power dissipation
- APD and PIN receiver options
- Data rates up to 11.3 Gbps
- +/-2.5 GHz frequency accuracy
- EU RoHS-6 compliant

## Applications

- Metro and long-haul 10 Gbps DWDM networks
- Replacement for legacy 300-pin transponders and fixed-wavelength transceivers.
- Metro ROADM
- Client-side and line-side

## ENABLING THE NEXT GENERATION COHERENT SYSTEMS

### 100 Gbps Integrated Coherent Transmitter (ICT) Platform for CFP2 and Beyond

EMCORE's 100 Gbps Integrated Coherent Transmitter Platform combines our industry-leading ultra-narrow linewidth tunable laser with the best-in-class InP modulator technology to meet the industry's demands for higher faceplate density and more power efficient Coherent platforms.



Growth in Coherent linecards and transponders is limited by size and cost, and fiber-coupling requires an extensive routing footprint. Lithium-Niobate is a large and expensive choice for modulators and new, more efficient Indium Phosphide (InP) technologies are available. EMCORE is an expert in Indium Phosphide (InP) wafer fabrication with a modular platform that has all the key ingredients for the integration of transmitter and receiver optics. The integration of EMCORE's low-noise tunable laser with our high-speed InP MZM technology delivers cost-effective 100 Gbps Coherent performance for next-generation CFP2 transceivers, enabling lower cost and reduced size 100G transponders.

## 100 Gbps ICT Platform Highlights

- Enabler of denser, more power efficient platforms
- Future-proof and scaleable
- Flex-grid and grid-less capable
- Ultra-narrow linewidth suitable for long-haul

## Applications

- 100 Gbps line cards and transponders
- Data center, metro long haul DWDM
- CFP2 transceivers
- Linecard ITXA



# CATV Broadband Overview

COMPONENTS, SUBSYSTEMS & SYSTEMS FOR CATV BROADBAND



**EMCORE Broadband designs and manufactures the most complete and advanced line of optical components, subsystems and systems for CATV broadband distribution networks. EMCORE's CATV products support various network architectures and address the needs of transmitting and receiving signals in short-to-long-haul, forward- and return-path, and headend-to-hub-to-node configurations over 1310 nm and 1550 nm wavelengths.**

EMCORE Broadband, through its Ortel heritage, was the first to implement linear fiber optic transmission for the cable industry and we continue to be a leader in providing RF over fiber products used in HFC networks in the CATV industry. Our products enable increased data transmission distance, speed and bandwidth, with lower noise and power consumption. This empowers cable service operators to offer multiple advanced services to meet the expanding demand for high-speed Internet, HDTV, video-on-demand, interactive video, and voice over IP (VoIP).

EMCORE's product portfolio includes forward and return-path analog and digital lasers, photodetectors and subassembly components, broadcast analog and digital fiber-optic transmitters, and Quadrature Amplitude Modulation (QAM) transmitters.

## CATV Broadband Highlights

- Most complete line of RF over fiber products for CATV networks
- Genuine Ortel linear fiber optic technology heritage
- Vertically-integrated solutions
- High-quality, high-volume manufacturing
- CWDM and DWDM wavelengths
- DOCSIS 3.1 compliant lasers

## CATV Broadband Distribution Network

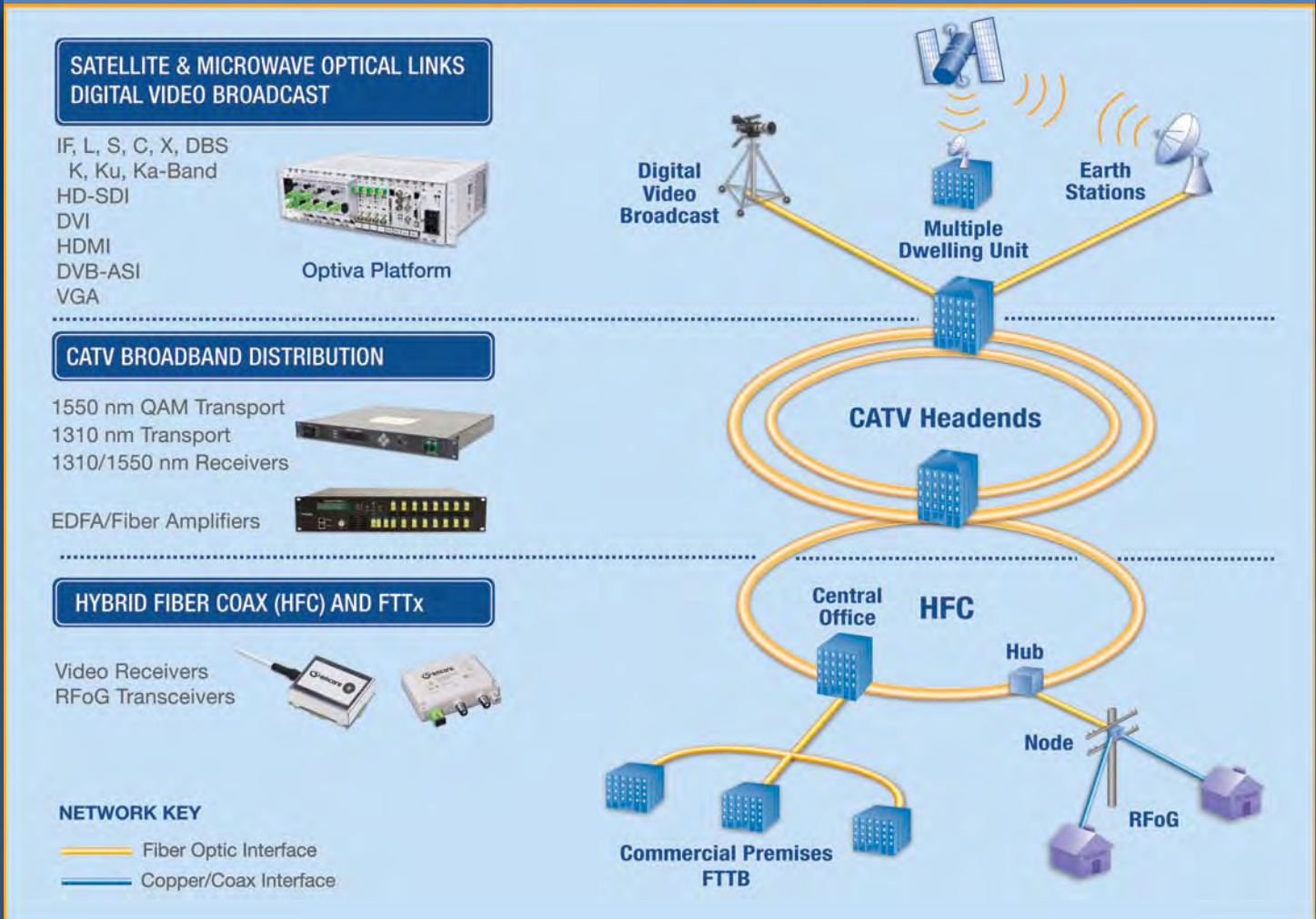

# CATV 1550 nm Fiber Optic Transmitters

DIRECTLY- AND EXTERNALLY-MODULATED FIBER OPTIC TRANSMITTERS



## Medallion 8000 Series Directly-Modulated CATV Transmitters

EMCORE's Medallion 8000 is a rack-mount directly-modulated DWDM CATV optical transmitter specifically designed for CATV or wideband applications



that require both CATV and DBS signals to be transmitted up to a 30 km length of fiber. The Medallion 8000 supports full 79-channel NTSC analog signals and/or a combination of QAM and DBS signals (with reduced channel analog CATV). It can be selected as a fixed fiber length option to support from 0 – 10 km, 5 – 15 km, 10 – 20 km or 15 – 25 km with 18 dBm SBS suppression maximum, or it can be ordered as a fiber length selectable option. This option allows the user to set the Medallion 8000 for best optimized CSO at any fiber length from 0 – 30 km with 1 km increments with up to 20 dBm SBS suppression.

## Medallion 6000 Series Externally-Modulated CATV Transmitters



### L-Type/D-Type/S-Type/F-Type/N-Type Transmitters

The Medallion 6000 series is a family of state-of-the-art high-performance 1550 nm externally-modulated CATV fiber optic transmitters optimized for varying network applications. Packaged in convenient 1 RU housing, this line of optical transmitters couples high optical output power, up to 11.0 dBm, with low optical linewidth resulting in unmatched performance. The optical modulator, combined with proprietary pre-distortion circuitry, provides superior CTB and CSO performance with SBS suppression levels of greater than 21 dBm. Advanced features such as built-in field adjustable SBS control and electronic dispersion compensation allow these transmitters to be quickly optimized in the field for any link or application without the need to procure specifically tuned transmitters.

### J-Type and I-Type Transmitters for Japanese & International Markets

Providing all the core capabilities of the Medallion 6000 series, J-Type Medallion transmitters are specially optimized to support fiber optic links of up to 150 km for the Japanese market place and other markets with similar requirements. The J-Type series is designed as a high-performance solution for CATV applications, or where the simultaneous transport of CATV and SAT-IF FM signals is required. The SAT-IF signals can be applied anywhere in the 950 to 2800 MHz band.

I-Type Medallion transmitters are optimized for international network applications that employ an 85 MHz forward / reverse path split frequency. This line of optical transmitters couples high optical output power, up to 10.0 dBm, with low optical linewidth resulting in unmatched performance. I-Type transmitters are specially designed and optimized to support fiber optic links of up to 150 km for the international marketplace.

## 1550 nm Transmitter Highlights

### Medallion 8000

- Field adjustable electronic dispersion compensation (EDC)
- Available on 100 GHz spaced ITU DWDM C-Band channels
- Optimized RF integration of pre-distorter, amplifiers, and EMCORE laser
- Advanced SBS suppression technology
- Fixed or fiber length selectable options
- RoHS compliant

### Medallion 6000

- Single or dual optical outputs
- QAM Loading to 1003 MHz
- Dual power supplies, redundant & hot-swappable
- Front panel RF test point
- SNMP control interface and WEB GUI
- Vacuum fluorescent status display
- OMI/RF gain adjustment
- AGC select: CW, video, manual (No AGC)
- Industry-leading field adjustable SBS suppression
- Field adjustable electronic dispersion compensation (EDC)

## Applications

- High power distribution networks
- High-performance supertrunking links
- Redundant ring architectures
- FTtx networks
- RFoG applications
- SAT-IF transport
- DWDM node splitting



# CATV 1550 nm Optical Amplification

ERBIUM DOPED FIBER AMPLIFIERS, OPTICAL SWITCHING

## Medallion 7000 Series CATV Amplifiers

The Medallion 7000 series are high-performance CATV fiber amplifiers optimized for the superior output power stability and exceptionally low noise figures demanded by CATV applications.



Medallion 7200 2RU

The Medallion 7200 is an Erbium-Ytterbium Doped Fiber Amplifier (EYDFA) packaged in a convenient 2 RU housing and the Medallion 7100 is a Erbium Doped Fiber Amplifier (EDFA) packaged in a 1 RU housing. Both of these fiber amplifiers provide very stable optical outputs over a wide operating temperature range. Internally they are supported with input and output isolators for enhanced system stability and performance.



Medallion 7100 1RU

All Medallion 7000 series fiber amplifiers offer a full range of flexible configurations and a rich set of features. These include remote management capability through SNMPv2, Telnet and a resident web server. The Medallion 7200 also supports MIBs specified by SCTE (Society of Cable Television Engineers) for this product class. For local management, an RS-232 port is standard, along with a convenient front panel control menu provided on a Vacuum Fluorescent Display (VFD).

## Optical Switches

### Medallion 2000 Optical A/B Switch

The Medallion 2000 Optical A/B Switch is a high-performance solution for network protection and optical redundancy. It provides an automatic or manual fiber switching function to protect the network from inadvertent



service outages due to up-stream optical signal degradation. If the primary fiber's optical signal power level falls below the desired optical trip threshold, the unit automatically switches to the secondary fiber, thus eliminating the need for intervention of a system operator. The Medallion 2000 is capable of manual switching or can be switched remotely via SNMP, Telnet or through a web browser, adding optical protection to many system applications. The Medallion 2000 is available in configurations of 1 to 4 independent optical switches per chassis.

The Medallion 2000 series is designed as a low power, cost effective, high performance switching solution for applications that demand reliable and rapid response to changing network conditions.

## 1550 nm EDFA Highlights

- High saturation output power
  - Up to 27 dBm – Medallion 7100
  - Up to 38 dBm – Medallion 7200
- Dual power supplies, redundant & hot-swappable – AC or DC
- Front panel optical input & output monitor ports
- SNMPv2 control interface
- Low noise figure for CATV
- Wide input dynamic range
- Very stable output power over a wide operating temperature range

## Applications

- CATV supertrunking
- Redundant ring architectures
- High power distribution networks
- FTtx networks

## Switching Highlights

- Automatic, manual and remote switching
- Auto-switching time less than 25ms
- SNMP control interface
- Front panel Vacuum Fluorescent Display (VFD) and LED indicators
- 1 RU rack-mount enclosure with choice of single- or dual-redundant AC or DC power supplies

## Applications

- Fiber optical protection switching
- Redundant ring architectures
- FTtx networks

# CATV 1310 nm Fiber Optic Transmitters & Receivers



## 2800 Series 1310 nm CATV Transmitters

The 2800 series transmitter family is a 1310 nm CATV Professional Distribution System (PDS) that transfers up to 79 channels of VSB/AM modulated signals over a singlemode optical fiber. The family is comprised of the models 2804 Generation II, 2805 and 2806 and is designed for use with EMCORE's 2800 series 1310 nm receivers. The 2804 Generation II and 2806 models are also suitable for transferring 79 CATV channels along with 30 digital QAM channels in the upper frequency range.

The 2804 Generation II and 2805 are 19" rack-mountable systems, while the 2806 is housed in a compact enclosure (3" x 8.5") that is one of the smallest in the CATV industry. The 2804 Generation II may be configured with a single transmitter or a unique dual transmitter option. The dual configuration doubles the density by allowing two active 1310 nm transmitters in a single 1 RU space. The 2806 can be mounted almost anywhere due to its small size and is a true plug-and-play system when used with 2808 or 2809 receivers.



2804 Generation II



2806

The 2800 series provides 40-870 MHz of usable bandwidth for video signals stacked at 6 MHz intervals. A low loss singlemode fiber allows full channel loading to beyond 20 km (10 km for 2806) while maintaining a good carrier-to-noise ratio.

## 2800 Series 1310 nm CATV Receivers

The 2800 series 1310 nm CATV receivers facilitate a low-cost system for transporting up to 79 channels of VSB/AM modulated signals over a singlemode optical fiber. This provides CATV distribution headend operators with an extensive array of features to increase system performance for intra-facility limited distance applications. The family is comprised of the 2807, 2808 and 2809 and is designed for use with EMCORE's 2800 series 1310 nm transmitter family.



2808

The 2807 Mini-Node CATV Optical Receiver, working with either the 2804 Generation II PDS or 2805 PNS (Private Network Solution) transmitters, provides an RF output of +38 dBmV over the entire optical input range allowing multiple RF splits without the use of an external RF amplifier. The 2808 79 Channel VSB/AM Optical Receiver provides an RF output of +28 dBmV and is equipped with a manual gain control that allows the user to adjust the RF output level for optimum performance.



2809

Additionally, the 2808's ability to operate over a wide optical input range of -8 to +4.5 dBm allows for a variety of system designs without degrading performance. The 2809, working with 2806 transmitter, provides excellent performance up to 10 km with full channel loading, high sensitivity, and 550 MHz of usable bandwidth.

## 1310 nm Transport Highlights

### Transmitters

- Transmit channels:
  - 2804 Generation II – 79 channels over a singlemode fiber. Dual transmitter option doubles density
  - 2805, 2806 – 79 channels over one singlemode fiber
- Transmission distances:
  - 2804 Generation II, 2805 – 20 km
  - 2806 – 10 km
- VSB/AM transmission ensures compatibility with standard CATV modulators and processors
- 2804 and 2805 transmitters includes status indicator LED's for easy assessment of performance
- 2806 has built-in, universal AC power supply eliminating bulky wall-mount AC adapters

### Receivers

- Receive channels:
  - 2807, 2808 – 79 channels
  - 2809 – 79 channels
- Wide Bandwidth:
  - 2807 – 50 to 860 MHz
  - 2808 – 40 to 860 MHz
  - 2809 – 40 to 550 MHz
- RF output over optical input range:
  - 2807 – +38 dBmV
  - 2808 – +28 dBmV
- Wide optical input range of -8 dBm to +4.5 dBm permits use of lower power transmitter, lowering costs
- Excellent picture quality with a CNR up to 54.5 dB, CSO of -63, and CTB of -66 dBm

### Applications

- Intra-facility multichannel medium to large campus video distribution
- CATV and FTTH HFC distribution networks
- 2804 Generation II ideal for smaller independent operators
- Broadband LANs
- Teleconferencing
- Multiple Dwelling Units (MDU)



# Lasers, Photodiodes & Plug-in Receivers

FOR CATV, FTTx, SATELLITE, WIRELESS, MILITARY SYSTEMS, CWDM & DWDM



EMCORE is a leading provider of fiber optic components for the transmission of analog video, voice and data signals over high-speed fiber optics. Our products, including bare die (or chip), TOSA, DFB CWDM and DWDM lasers, and PIN and avalanche photodiodes (APD), support a wide variety of broadband, satellite, wireless and telecom applications.

EMCORE lasers utilize Genuine Ortel Technology which has symbolized the highest quality in linear high-speed photonics. EMCORE leverages our Ortel heritage in linear fiber optics, combined with our vertically-integrated infrastructure and high-volume manufacturing to deliver the highest quality fiber optic components available today.

## DOCSIS 3.1 1550 & 1310 nm Laser Modules



EMCORE's 1752A, 1550 nm and 1616A, 1310 nm DOCSIS 3.1 lasers are designed specifically for CATV applications and are compliant with the new DOCSIS 3.1

standard. These lasers support operational bandwidth up to 1.2 GHz and feature low adiabatic chirp to maximize signal quality in short and long lengths of fiber. The lasers operate over an industrial temperature range with excellent inherent linearity to minimize degradation of broadcast signals.

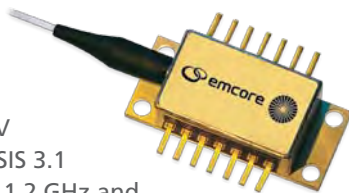

## 1900 Series Coaxial TO-56 DFB Lasers



EMCORE's 1933, 1935 and 1955 coaxial TO-56 DFB lasers offer a low cost solution for linear fiber optic links. They can be cooled with external thermo-electric coolers for high stability, or run without TEC's to reduce power consumption. These DFB lasers are packaged in a compact, hermetic assembly with monitor photodiode and isolator for flexible integration into various transmitter designs.

## 1600 Series 1310 nm 14-pin Butterfly DFB Lasers

EMCORE's 1612, 1615 and 1622, 1310 nm forward path DFB laser modules are designed for both broadcast and narrowcast analog applications. These highly linear devices feature optical output power options up to 100 mW with superior distortion performance over an enhanced temperature range of -40° C to +85° C.

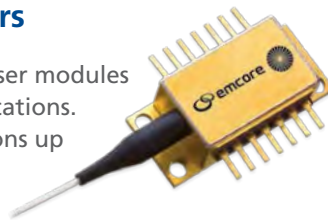

## 1700 Series 1550 nm DWDM 14-pin Butterfly DFB Lasers

EMCORE's 1751, 1754 and 1782, 1550 nm laser modules feature a distributed feedback chip that has been designed specifically for RF QAM and CATV applications. They feature low adiabatic chirp to maximize signal quality in short and long lengths of fiber. The laser's excellent inherent linearity minimizes degradation of broadcast signals caused by QAM channels.

## 7820 Series Optical Receivers



The 7820 series CATV optical receivers are a single-mode fiber pigtailed modules featuring a low-noise, impedance-matched broadband photodiode and RF amplification. These devices receive optical analog and/or digital signals for a range of video broadcast options, and deliver the corresponding RF electrical output. The 7820A model supports the delivery of up to 110 CATV analog signals, or a combination of analog and digital channels, including HDTV broadcast.

## Laser & Receiver Highlights

- Wide temperature range operation:  
-40° C – 85° C (Lasers)  
-30° C – 85° C (Receivers)

### 14-pin Butterfly

- DOCSIS 3.1 compliant models
- High optical output power options up to 100 mW
- OC-48 pinout compatible
- Cooled or uncooled operation

### Coaxial TO-56

- 10 MHz to 6 GHz DFB lasers for broadband applications
- High-slope efficiency up to 0.3 mW/mA
- High optical output power available up to 10 dBm
- Low power consumption
- RoHS compliant

### Optical Receivers

- Supports 1310 and 1550 nm forward- and return-path video transport
- Next-generation small form-factor (17.8 mm x 21.8 mm)
- Ultra-low noise
- Wide bandwidth up to 6000 MHz

### DFB Laser Applications

- Forward- and return-path commercial CATV networks
- Satellite earth stations
- Mobile phone antenna sites
- Wireless/Distributed Antenna Systems
- Military systems

### Optical Receiver Applications

- Video signal distribution in HFC and FTTx nodes and PON video overlay

# Wireless & Distributed Antenna Systems (DAS)

LASERS, OPTICAL RECEIVERS AND FIBER OPTIC LINKS

The increasing dependence on wireless networks for social media, texting, email, and uploading and downloading of apps, music, videos and photos have created greater demand for deployment of cost-effective, integrated wireless Distributed Antenna Systems (DAS). Wireless systems providers are building systems in subway tunnels, stadiums, high-speed trains and cruise ships. EMCORE's linear DFB Lasers, Optical Receivers and Fiber Optic Links integrate extremely well into these systems, enhancing bandwidth to enable the delivery of consistent, reliable signals in areas where interference is high, or signals are weak.

## 1764 1550 nm C-Band DWDM DFB Laser

EMCORE's 1764 1550 nm laser module is a DWDM laser that features a distributed-feedback (DFB) device that has been designed specifically for RF and wireless applications. The 1764 laser has a wide temperature range for reliable performance in harsh node environments and narrow transmitter designs. It also features low adiabatic chirp to maximize signal quality in short and long lengths of fiber. The 1764 is available in all C-Band ITU grid wavelengths.

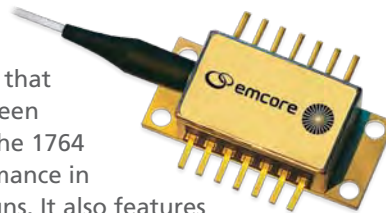

## 1615A 1310 nm DFB Laser Module

Also designed for both wireless and distributed antenna system applications, the 1615A 1310 nm DFB Laser Module is a highly-linear device that delivers superior distortion performance over an enhanced temperature range of -40°C to +85°C.

## 7830W 3 GHz Optical Receiver

EMCORE's 7830W 3 GHz optical receiver is a singlemode fiber pigtailed module featuring a low-noise, impedance-matched broadband photodiode and RF amplification. The device receives optical analog and/or digital signals for a range of video broadcast options, and delivers the corresponding RF electrical output.



## 3 GHz & 6 GHz Fiber Optic Links for Wireless

### Packaged Modules

EMCORE's 3 GHz and 6 GHz Fiber Optic Links (FOL) for wireless signals are cost-effective, high-performance broadband transmitter, receiver, and transceiver modules designed for wireless interfacility link applications. Each module is packaged in a rugged cast metal housing and optional 50 Ohm SMA or 50/75 Ohm BNC connectors are available for versatile interface applications. Transmit and receive alarms/indicator simplify installation and provide operational status.

The optional FOL-CC-5-1U 1 RU 19" rack-mount unit is an EIA-310D standard design to hold up to five FOL modules. It has a built-in universal dual power supplies, front panel indicators for visual indications of power supply operation and cumulative link status.

### PCB Modules

EMCORE 3 GHz and 6 GHz Fiber Optic Link PCB Modules (FOB) are designed for wireless interfacility link applications and feature optimal optical power stability for assured performance over full temperature range. These compact, pluggable PCB modules include built-in EMI/RF shielding.



## Wireless Highlights

### DFB Lasers

- Standard ITU grid wavelengths
- Advanced analog chip design
- Wide industrial temperature range – stable even in harsh environments
- Telcordia® 468 compliant
- RoHS compliant

### Optical Receivers

- Wide 40 MHz – 3000 MHz Bandwidth: Supports analog or a combination of analog and digital channels
- Case temperature range from -30°C to +85°C
- Excellent RF frequency and distortion characteristics for high linearity
- Internal proprietary impedance matched circuitry

### Fiber Optic Links

- Packaged Modules: 100 KHz – 3 GHz & 100 KHz – 6 GHz RF fiber optic links
- PCB Modules: 1 MHz – 3 GHz & 1 MHz – 6 GHz RF fiber optic links
- 3 μm or 1.5 μm low noise isolated DFB laser
- Internal Tx RF pre-amplifier
- Automatic optical power control
- LD/PD monitoring and alarm
- Rugged dust-tight housing (Packaged Modules)
- Optional 1 RU 19" rack-mount enclosure (for Packaged Modules)

## Laser & Receiver Applications

- Wireless networks
- Distributed Antenna Systems (DAS)
- Architectures using separate optical wavelengths to carry targeted services
- Long distances and high optical splits

## Fiber Optic Link Applications

- 4G LTE and WiMAX
- Distributed Antenna Systems (DAS)
- Cellular backhaul



# Fiber-To-The-Premise (FTTP) & RFoG

TRANSCEIVERS, LASERS & PHOTODIODES FOR VIDEO, VOICE AND DATA



EMCORE has developed customer qualified FTTP components and subsystems to support deployments of fiber optics-based access networks for homes and businesses. Our FTTP products include RFoG optical transceivers, PON transceivers, analog fiber optic transmitters for video overlay with high-power Erbium Doped Fiber Amplifiers (EDFA), plus analog and digital lasers, photodiodes, and video receivers.

## RFoG Optical Transceivers, Lasers & Photodiodes

EMCORE's RFoG transceivers supports 1310/1590/1610 nm burst mode analog return-path conversion for triple-play voice, video and data signals in SFU (Single Family Unit) and MDU (Multi-Dwelling Unit) applications. They feature a 1 GHz or 2.7 GHz bandwidth downstream receiver that supports digital or QAM upstream transmission. EMCORE RFoG lasers include 1310 nm, 1590 nm, 1610 nm DFB or Fabry-Perot (FP) lasers modules with integrated WDM, plus a photodiode with WDM filter.



## 9936F Integrated PON & 9937D Integrated GPON Triplexers for FTTP



EMCORE's integrated PON and GPON triplexers are high-performance, burst-mode optical transceivers for triple-play for voice, video and data applications. They are designed to perform the O/E and E/O conversion in a PON or GPON system and are robustly designed for outdoor environments.

The 9936F features a 1310 nm FP laser with burst-mode laser driver, a 1490 nm PIN for data, and a 1550 nm PIN with AGC amplifier for received video signals. It is offered with pins on the bottom side contacts for easy integration into a motherboard and SMB for video. This high-performance package has been designed to resist ESD and EMI interference.

EMCORE's 9937D transceiver is a high-performance, burst-mode transceiver for GPON systems with video overlay (Asymmetric 1244.16 Mb/s upstream / 2488.32 Mb/s downstream).

## FTTP Highlights

### RFoG Transceiver

- Supports 1310/1590/1610 nm burst mode analog return-path
- Supports digital or QAM upstream
- SFU and high-power output MDU options available
- PON compatible

### PON & GPON Transceivers

- Triple-play solution for voice, video, and data in a PON or GPON system
- Burst mode transmitter: 1310 nm DFB-LD upstream
- Continuous mode receiver: 1490 nm APD with bandpass filter
- Integrated analog CATV receiver: 1550 nm InGaAS PIN-PD

## Applications

- Fiber-To-The-Node
- Fiber-To-The-Premise
- SFU and MDU
- PON and RFoG networks

## End-to-End FTTx with Video Overlay

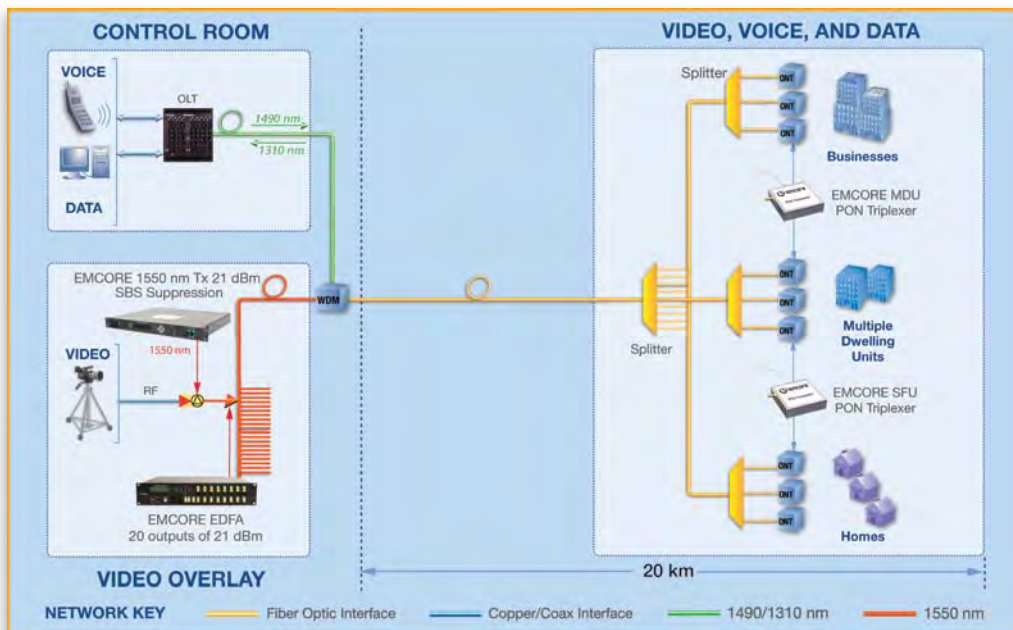



# EMCORE Innovation & Technology Leadership

EMCORE is a vertically-integrated manufacturer that pioneered the MOCVD (Metal-Organic Chemical Vapor Deposition) process for both development and production of virtually all compound semiconductor-based materials and devices in use today. EMCORE owns and operates semiconductor wafer fabrication plants at our corporate headquarters in Albuquerque, New Mexico and at our fiber optics headquarters in Alhambra, California.

EMCORE's vertical integration and differentiated External Cavity Laser (ECL) platform positions us for leadership in the development of enabling technologies for current and future high-speed telecommunications networks where Coherent transmission is expanding to metro and 400 Gbps applications. EMCORE's highly-linear fiber optics capability based on Genuine Ortel Technology allows us to continue to be a leader in providing RF over fiber products for HFC networks in the cable industry.

EMCORE's combination of semiconductor manufacturing expertise and advanced photonics design capability has enabled us to achieve strong penetration in the Telecommunications and CATV markets.

## Quality Management - ISO 9001 Certified

EMCORE's various manufacturing processes involve extensive quality assurance systems and performance testing. Our manufacturing facilities have all acquired and maintain ISO 9001 certification.

## How To Contact

For more information about EMCORE solutions for Telecommunications, CATV Broadband, Wireless and FTTP, visit [www.emcore.com](http://www.emcore.com), or contact us below.

---

## EMCORE Fiber Optics

### North America

#### Telecom/Digital Products

8674 Thornton Avenue  
Newark, CA 94560 USA

**P** +1 510-896-2100

**F** +1 510-896-2133

#### CATV Broadband

2015 Chestnut Street  
Alhambra, CA 91803 USA

**P** +1 626-293-3400

**F** +1 626-293-3428

### Europe, Middle East, Africa

#### Telecom/CATV Broadband

**P** +44-1344-827-306

### China, Asia/Pacific Rim

#### CATV Broadband

**P** +86-13-828737578

## Email

For EMCORE Telecommunications products, email [telecom-sales@emcore.com](mailto:telecom-sales@emcore.com).

For EMCORE CATV Broadband, Wireless and PON products, email [catv-sales@emcore.com](mailto:catv-sales@emcore.com).